

AirBasic®

WINDSIFTING | PRODUCT PRESENTATION

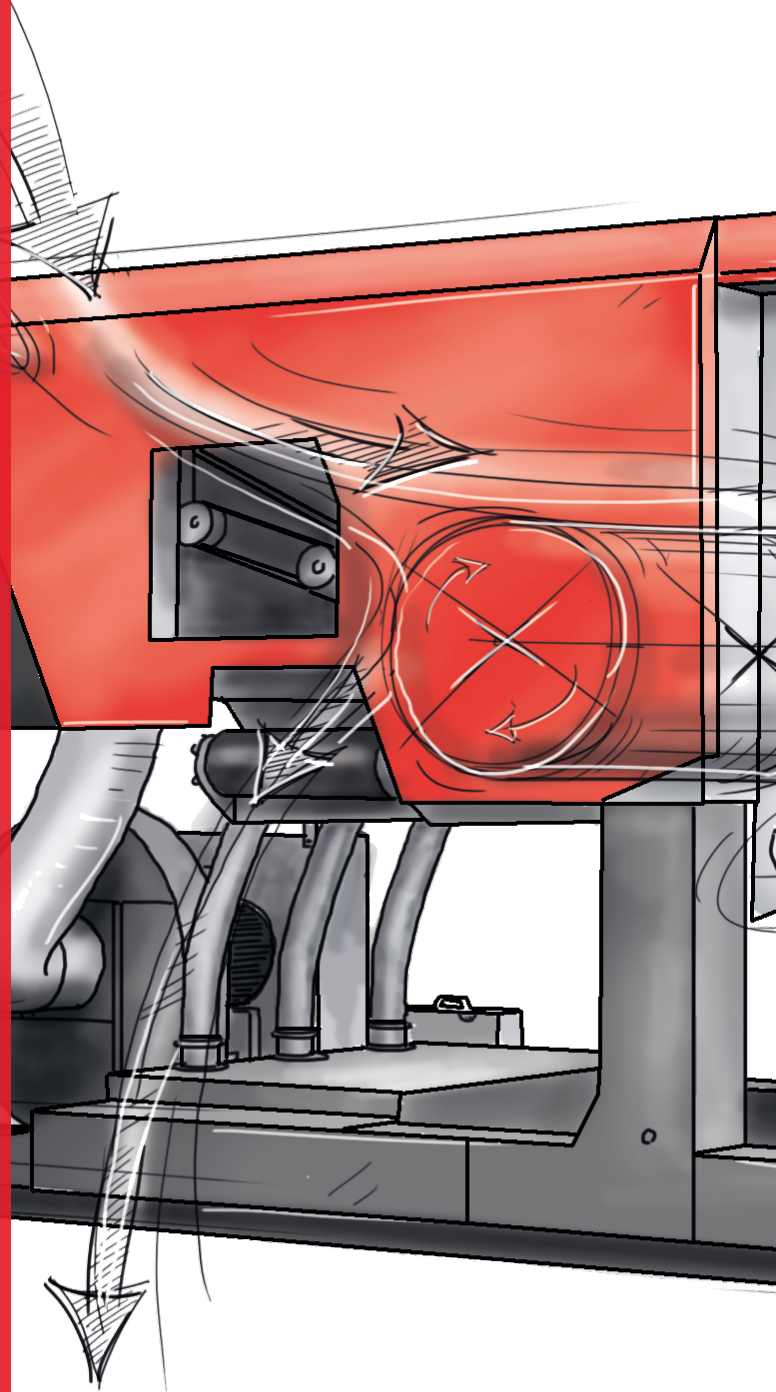

heavy

AirBasic®

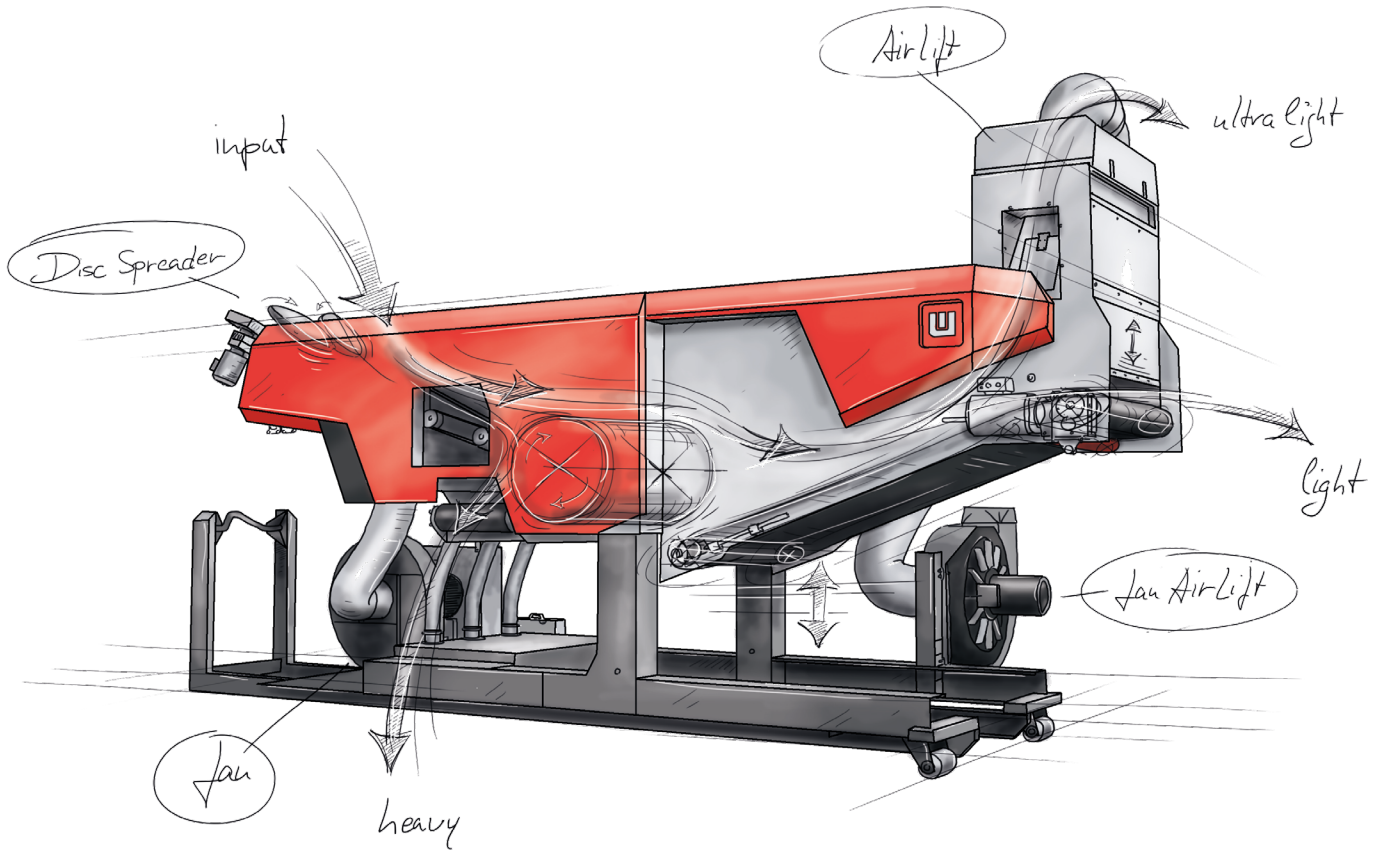

Compact system for flexible solutions

The AirBasic brings the advantages of our proven windsifter technology to a small, mobile machine. It is available in different options to ensure optimum separation results at any location. Material can be fed in any direction (180 °). It has a patented adjustable and

precise nozzle system that works much more efficiently than comparable products on the market. Thanks to our standardized production process, it can be delivered fast, regardless of the version or options selected. Fully equipped, it fits into only one 40ft HC container.

About us

Westeria is a German company from Westphalia with over 60 years of experience producing innovative machinery. Since 1956, our product portfolio has largely grown to provide high-quality machines, technical expertise and excellent service to our clients. We are constantly developing new recycling machines and conveyor systems for what is perhaps the biggest challenge of the present day: make the circular economy a valuable and profitable reality all over the world.

Components

The windsifter is composed of the following parts:

AirBasic®

The main body of this machine consists of a two-way separation system that can easily integrate conveyors or other modules such as the AirLift or DiscSpreader to adapt to your needs.

Acceleration belt

Belt that feeds material to a speed of up to 2,16 m/s.

Patented air system

Highest purity of output fractions due to marginal deviation of blowing velocity (max. 5 % at 1,500 mm operation width).

Separation drum

Rotating drum that separates the heavy and light material.

The position of all crucial components of the system can be reproduced with the help of a coordinate system.

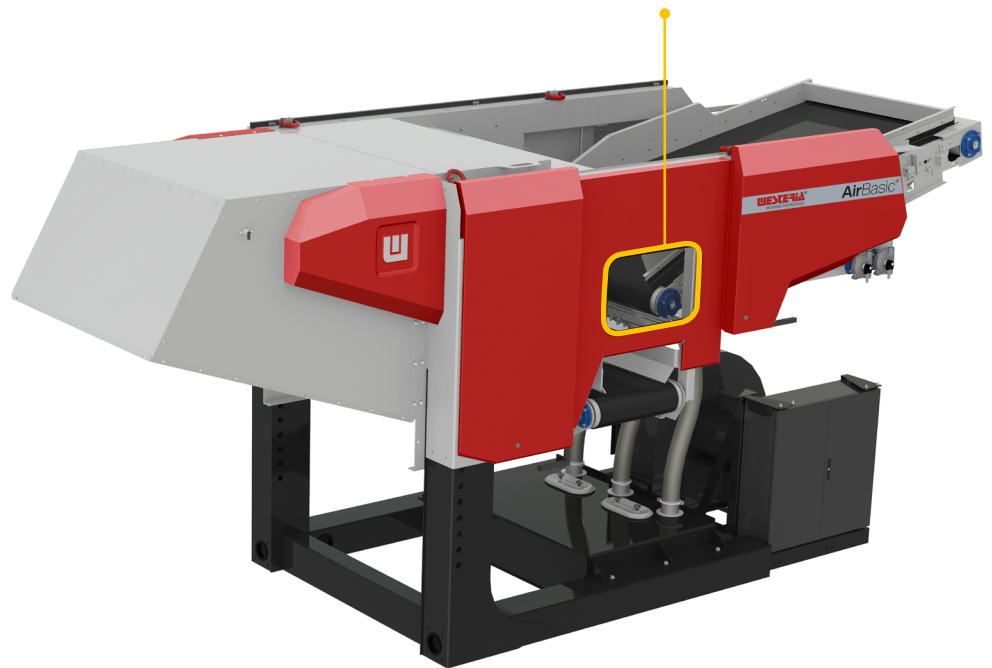

Key advantages

Maximal flexibility

Many options can be integrated to adapt the machine to your needs.

Easy maintenance

Free access to all components in operation position.

Energy-saving

Low system resistance allows higher pressure at the blower nozzle with the same fan power.

Application examples



Technology Center

We will test the performance of your materials at our Technology Center and we give you assurance that you will achieve the same results with your application.



- Remove films and packaging from compost or household waste
- Remediate waste directly in landfills
- Separate C&D waste
- Process PET bottles to separate light plastics and label papers
- Separate slag to benefit from these combustion residues
- Recycle even the toughest scrap materials without damaging this robust machine

Options

Can be added to match your needs.

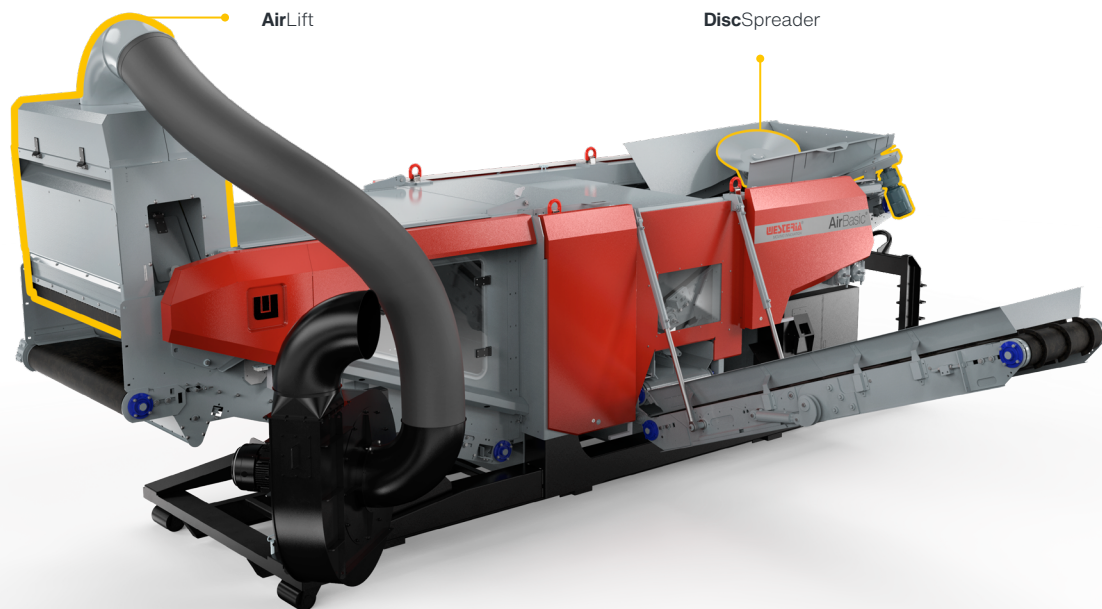

AirLift®

Vacuum windsifting machine that creates a third fraction by separating ultra-light impurities from light fraction.

DiscSpreader®

Material distribution machine that feeds smooth flows of non-linear material inputs.

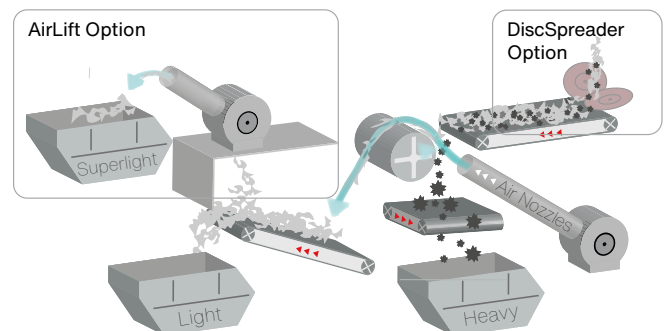

Mobility

Different carriages can be integrated to simplify transport and to achieve absolute mobility:

- Fork lift carriage
- Hook lift carriage
- Tow coupling and wheel chassis
- Crawler chassis (with remote control)

Conveyors

Depending on requirements, the following Westeria conveyors can be installed:

- Light discharge conveyor (max. height: 2525 mm)
- Lateral conveyor (heavy discharge)
- Pile conveyor (hydraulically retractable, max. height: 2915 mm)

Hydraulic level control

Optimal working height quickly and easily adjusted (max. 800 mm).

With roll on/off frame and small light fraction chamber

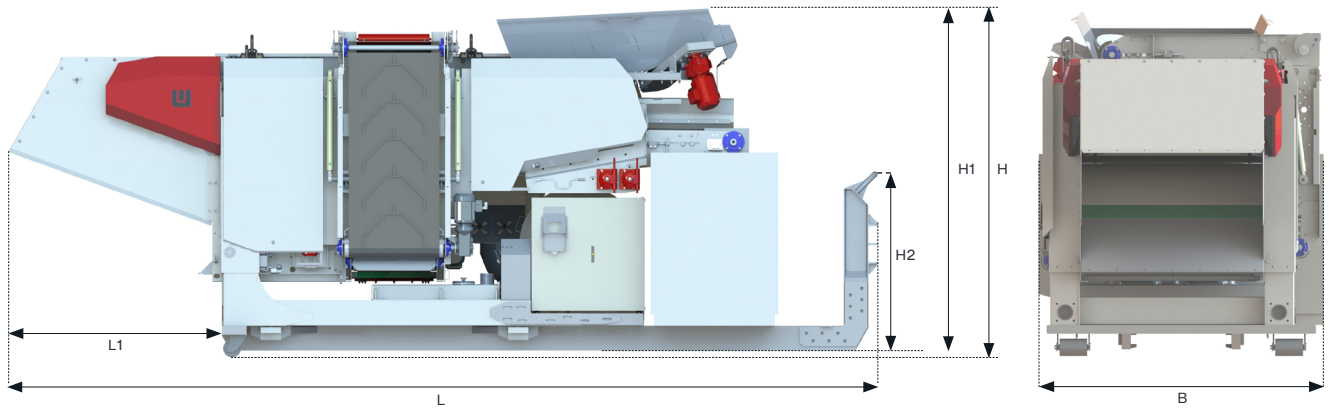

With generator	L (mm)	B (mm)	H (mm)	W (kg)	L1 (mm)	H1 (mm)	H2 (mm)
Basis	7704	2550	2732	8600	1899	2672	1570
Lateral conveyor	7704	2550	2732	+300	1899	2672	1570
Pile conveyor	7704	2550	2892	+670	1899	2832	1570
DiscSpreader	7704	2550	2945	+450	1899	2885	1570
Without generator	L (mm)	B (mm)	H (mm)	W (kg)	L1 (mm)	H1 (mm)	H2 (mm)
Basis	7704	2476	2532	6800	1899	2472	1570
Lateral conveyor	7704	2476	2532	+300	1899	2472	1570
Pile conveyor	7704	2523	2692	+670	1899	2632	1570
DiscSpreader	7704	2476	2745	+450	1899	2685	1570

With roll on/off frame and big light fraction chamber

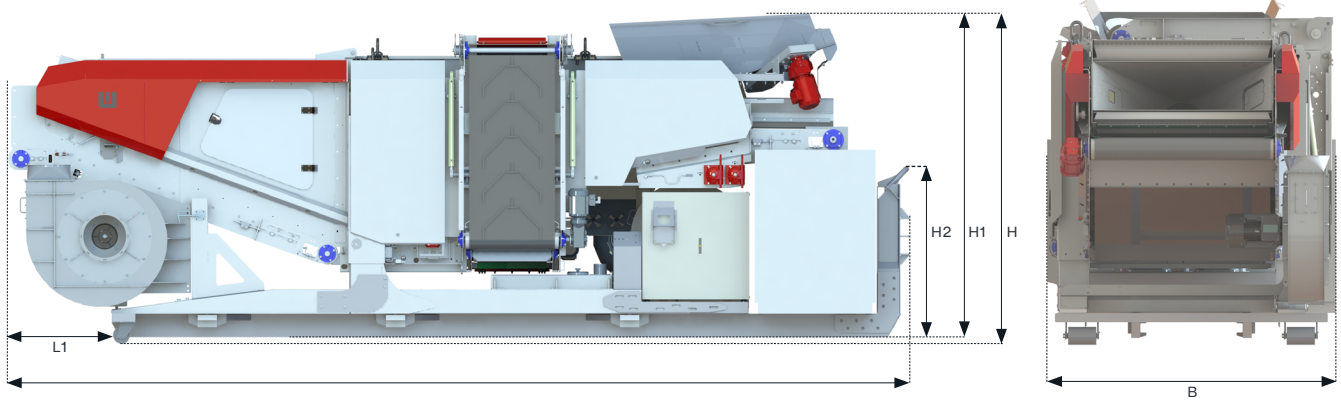

With generator	L (mm)	B (mm)	H (mm)	W (kg)	L1 (mm)	H1 (mm)	H2 (mm)
Basis	8425	2550	2758	10880	970	2698	1570
Lateral conveyor	8425	2550	2758	+300	970	2698	1570
Pile conveyor	8425	2550	2892	+670	970	2832	1570
DiscSpreader	8425	2550	2945	+450	970	2885	1570
AirLift	8425	2550	2758	+1300	970	2698	1570
Without generator	L (mm)	B (mm)	H (mm)	W (kg)	L1 (mm)	H1 (mm)	H2 (mm)
Basis	8425	2476	2558	9100	970	2498	1570
Lateral conveyor	8425	2476	2558	+300	970	2498	1570
Pile conveyor	8425	2523	2692	+670	970	2632	1570
DiscSpreader	8425	2476	2745	+450	970	2685	1570
AirLift	8425	2531	2558	+1300	970	2498	1570



Westeria® GmbH

Raiffeisenstr. 2, 48346 Ostbevern, Germany
Tel +49 2532 88-0 | www.westeria.de

03/2023