

**W WeKea®**

CONVEYING | PRODUCT PRESENTATION

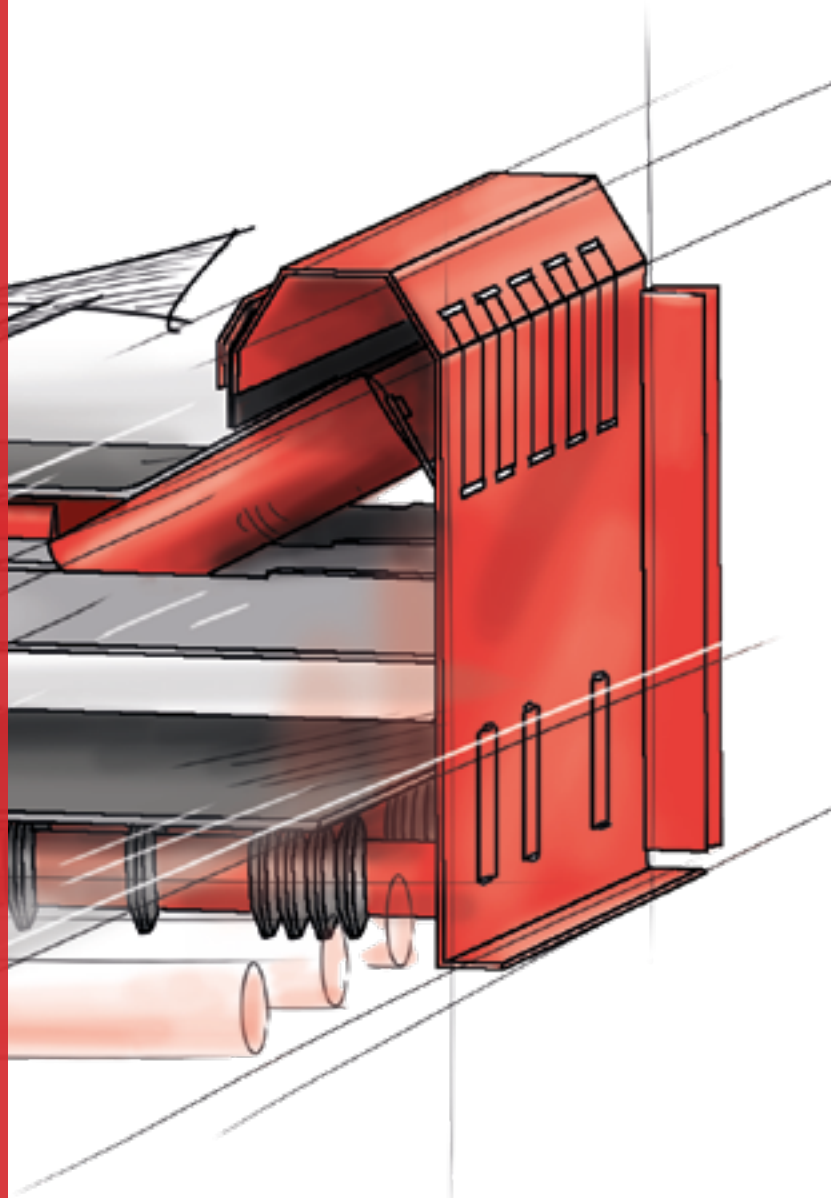

## Making conveying systems modular

Westeria has revolutionized the conveyor procurement process: WeKea is a modular series of conveyors with an online configurator that gives you an official quote in within minutes. The design of the conveyors allows delivery in an incredibly short time and requires much less freight space. All this, with the highest commitment to quality as you have come to expect from Westeria conveyors.

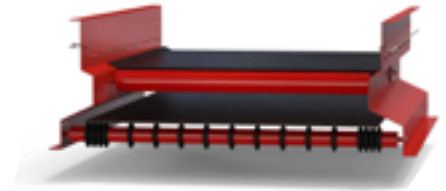

FlatCon®

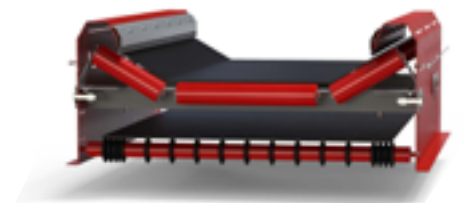

UCon®

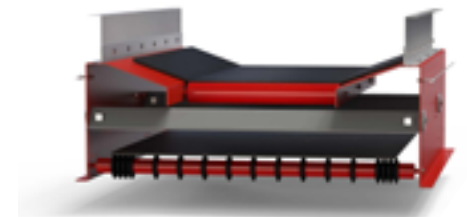

SteelCon®



ChainCon®



---

## About us

Westeria is a German company from Westphalia with over 60 years of experience producing innovative machinery. Since 1956, our product portfolio has largely grown to provide high-quality machines, technical expertise and excellent service to our clients. We are constantly developing new recycling machines and conveyor systems for what is perhaps the biggest challenge of the present day: make the circular economy a valuable and profitable reality all over the world.

# Key advantages

## Quick and easy configuration

Every application is different. But we still believe that getting a quote for a conveyor should be easy. That's why we put a lot of work into designing the WeKea configurator.

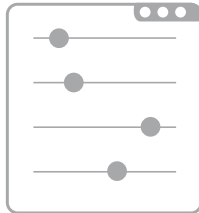

## Planning certainty

Within seconds, you will receive an official quotation and an approvable 3D drawing. This allows you to proceed immediately with the further planning of your project.

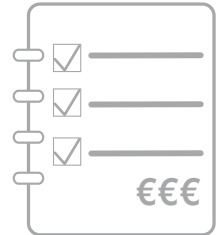

## The conveyors

After five years of development and optimization, we have succeeded in offering five conveyor belt types in the WeKea configurator: FlatCon, UCon, SteelCon, ChainCon and PlateCon. The challenge was not only to standardize all parts and components, but also to keep the whole system as flexible as you are used to from Westeria.

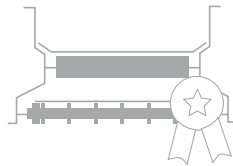

## Fast and efficient delivery

Every part has been designed to be as space-saving as possible, down to the smallest detail, in order to minimize freight costs. Most parts are already in stock and thanks to the WeKea modular system your local staff can assemble the belts themselves.



## Configurator

- Real-time price calculator
- Intuitive design
- Quote is generated instantly
- Support from our Westeria sales team
- Automatic generation of approvable 3D drawings

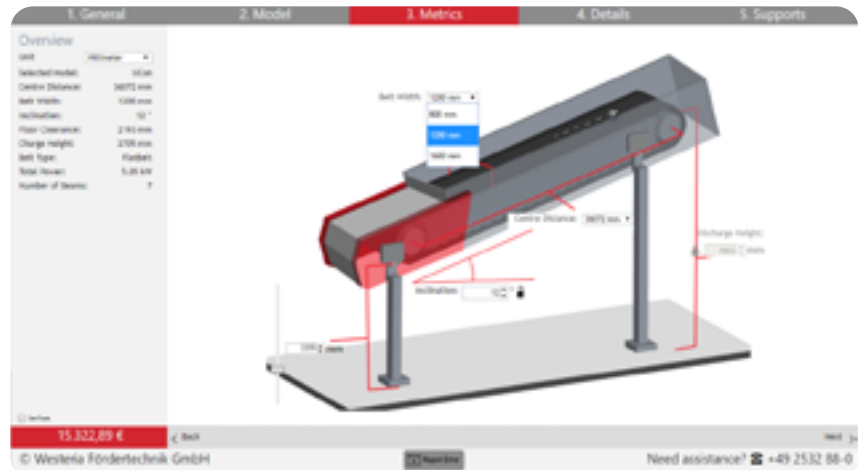

## Modular System

- Extremely economical transport volume
- Fast delivery times
- Assembly by local personnel possible
- Also available as pre-assembled conveyors
- Precise calculation of transport volume and weight



## We are happy to advise you

In a non-binding online appointment, we will demonstrate our online configurator and explain to you what is possible with it. From configuration to quotation and 3D download, you can learn all the details. Our customers report that usually 90% of the conveying tasks in a plant can be handled with WeKea standard belts. The remaining 10% can be solved by using our WeKea customized program.

# Application



WeKea conveyors are suitable for all recycling and bulk material processing applications.

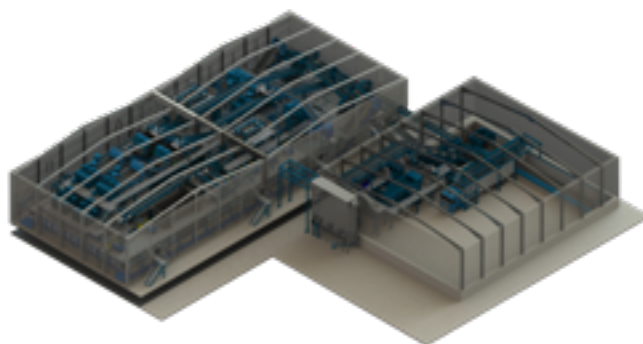

# Module

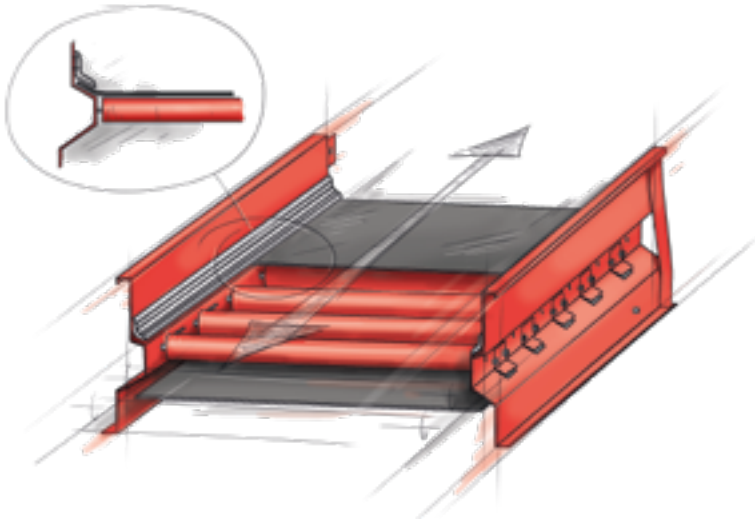

## FlatCon®

- Optimum side sealing
- Energy-saving drive power
- Extremely versatile

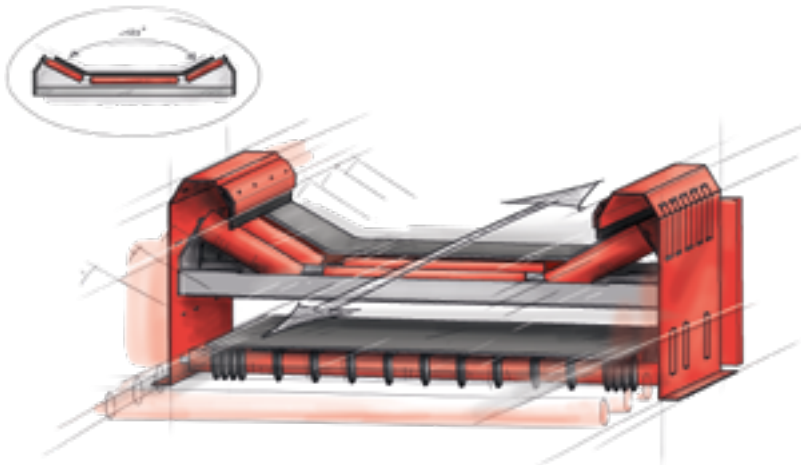

## UCon®

- Ideal for all bulk materials
- Proven and optimized for years
- Easily accessible idlers even with side sealing

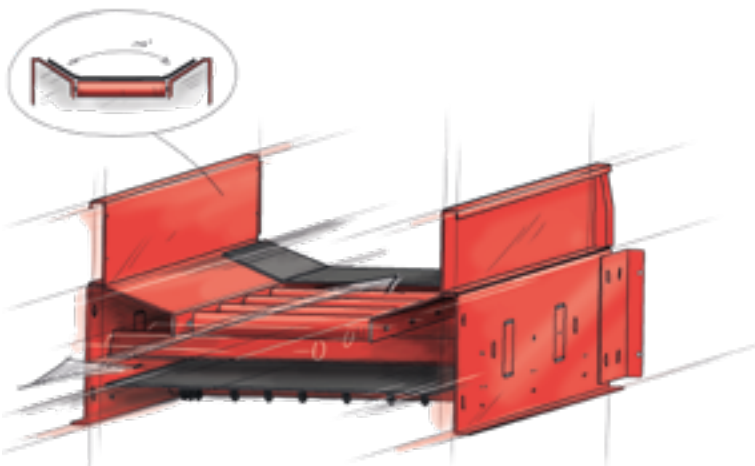

## SteelCon®

- Perfect for the toughest applications
- Long service life even under heavy use
- Reduction of wear parts

Standard belt widths for all modules	800 mm	1200 mm	1600 mm
Min. Center distance	2412 mm	2907 mm	3402 mm
Max. Center distance	40032 mm	40032 mm	40032 mm

## ChainCon

- Steep belt conveyor with chain drive
- Completely redesigned: durable and extremely easy-to-maintain components
- Withstands highest operation demands
- Automatic chain oiling with active pump, 30L tank and level warning
- Lubrication at the optimum position results in significantly longer chain life without additional labor
- Shock load is transferred directly to supports so chain is not stressed
- Complete overhaul possible in a cost-efficient way, thanks to easy-to-change chain guide, easy-to-change drive or idler shaft and other easily accessible components
- Chain with 140,000 N breaking load

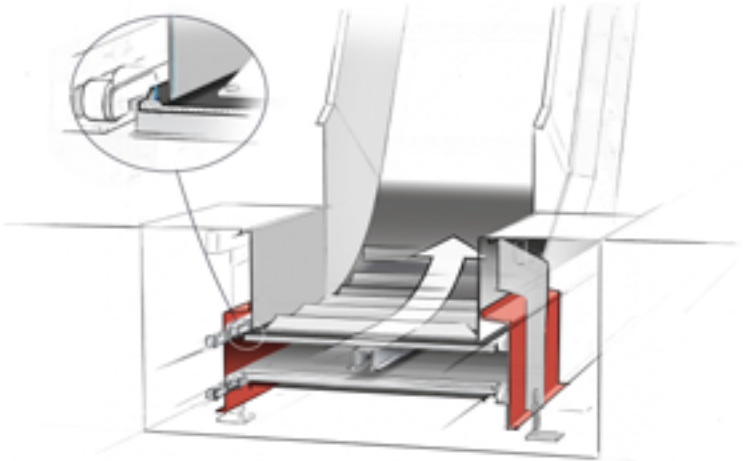

## WeKea® customised

If your requirements do not fit one of our configurable modular conveyors, with the WeKea customized program we can produce individually designed conveyors with our series-produced components, which reduces production costs and shortens delivery times.





Westeria® GmbH

Raiffeisenstr. 2, 48346 Ostbevern, Germany  
Tel +49 2532 88-0 | [www.westeria.de](http://www.westeria.de)